

FLEX-A-SEAL STYLE 01
O-RING GROOVE SEAT

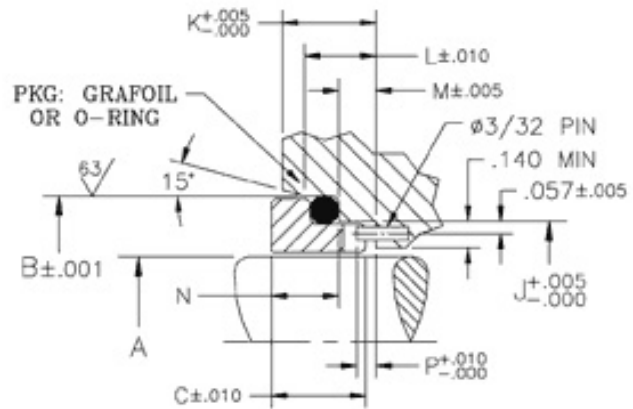

FLEX-A-SEAL STYLE 03

DASH NO.	"A" SHAFT DIA.	"B" GLAND BORE DIA.	"C" SEAT THK.	"D" GLAND CAVITY DEPTH	STYLE 01 O-RING SIZE	"J" CAVITY STEP DIA.	"K" CAVITY DEPTH	"L" DEPTH	"M" STEP DEPTH	"N"	"P" PIN LENGTH	STYLE 03 O-RING SIZE
12	0.750	1.375	0.406	0.344	216							
14	0.875	1.500	0.406	0.344	218							
15	0.937	1.562	0.437	0.375	219							
16	1.000	1.625	0.437	0.375	220	1.384	0.486	0.390	0.240	0.261	0.156	220
18	1.125	1.750	0.437	0.375	222	1.509	0.486	0.390	0.240	0.261	0.156	222
20	1.250	1.875	0.437	0.375	223	1.634	0.486	0.390	0.240	0.261	0.156	223
22	1.375	2.000	0.437	0.375	224	1.759	0.486	0.390	0.240	0.261	0.156	224
24	1.500	2.125	0.437	0.375	225	1.884	0.486	0.390	0.240	0.261	0.156	225
26	1.625	2.375	0.500	0.437	227	2.134	0.508	0.431	0.251	0.314	0.165	227
28	1.750	2.500	0.500	0.437	228	2.259	0.508	0.431	0.251	0.314	0.165	228
30	1.875	2.625	0.500	0.437	229	2.384	0.508	0.431	0.251	0.314	0.165	229
32	2.000	2.750	0.500	0.437	230	2.509	0.508	0.431	0.251	0.314	0.165	230
34	2.125	3.000	0.562	0.500	232	2.759	0.589	0.480	0.300	0.346	0.216	232
36	2.250	3.125	0.562	0.500	233	2.884	0.589	0.480	0.300	0.346	0.216	233
38	2.375	3.250	0.562	0.500	234	3.009	0.589	0.480	0.300	0.346	0.216	234
40	2.500	3.375	0.562	0.500	235	3.134	0.589	0.480	0.300	0.346	0.216	235
42	2.625	3.375	0.625	0.562	235	3.134	0.663	0.521	0.341	0.379	0.232	235
44	2.750	3.500	0.625	0.562	236	3.259	0.663	0.521	0.341	0.379	0.232	236
46	2.875	3.750	0.625	0.562	238	3.378	0.618	0.475	0.225	0.450	0.140	340
48	3.000	3.875	0.625	0.562	239	3.503	0.618	0.475	0.225	0.450	0.140	341
50	3.125	4.000	0.625	0.562	240	3.628	0.618	0.475	0.225	0.450	0.140	342
52	3.250	4.125	0.625	0.562	241	3.753	0.618	0.475	0.225	0.450	0.140	343
54	3.375	4.250	0.625	0.562	242	3.878	0.618	0.475	0.225	0.450	0.140	344
56	3.500	4.375	0.625	0.562	243	4.003	0.618	0.475	0.225	0.450	0.140	345
58	3.625	4.500	0.687	0.562	244	4.128	0.706	0.521	0.271	0.492	0.174	346
60	3.750	4.625	0.687	0.562	245	4.258	0.706	0.521	0.271	0.492	0.174	347
62	3.875	4.750	0.687	0.562	246	4.378	0.706	0.521	0.271	0.492	0.174	348
64	4.000	4.875	0.687	0.562	247	4.503	0.706	0.521	0.271	0.492	0.174	349

MATING RING & GLAND
CAVITY DIMENSIONS
TYPES 01 & 03

FLEX-A-SEAL, INC.
P.O. BOX 184/ 1 JACKSON ST.
ESSEX JUNCTION, VT 05453
(802) 878-8307

DRAWING NO.:
SK1611

SCALE: NONE DRAWN BY: DD DATE: 6/12/01

SIZE

REV.